



#### ■ Features

- Can continuously carry 2080W internal resistive loads , and the instantaneous power is more than 2 times.
- No load power (< 10W).
- With the most advanced load resolution、 overload protection、 short circuit protection technology.
- With input multiple voltage range options 12,24,36,48V, output 110/220V frequency:50/60Hz.
- Lifespan more than 10000 hours(5 hours per day and more than 5 years).

#### ■ Description

The LGE-2080W series is an inverter designed by the Power Division of Shenzhen Green Power New Energy Co., Ltd. The design concept is based on the principle of AC power generators. By using software-based SPWM integral calculus algorithm and LC resonant modulation technology, it achieves the optimal output of pure sine wave AC power for loads, with high compatibility and load-bearing capacity as its design features. With a high conversion efficiency of up to 94%, it employs intelligent fan management control, allowing it to operate in environments ranging from -30 degrees to 60 degrees Celsius.

#### ■ Application

- Electric cooker
- Hairdryer
- Air conditioner
- Teakettle
- Multifunctional pot appliance
- Portable electric working tools and other common daily electrical appliances

#### ■ Model Code

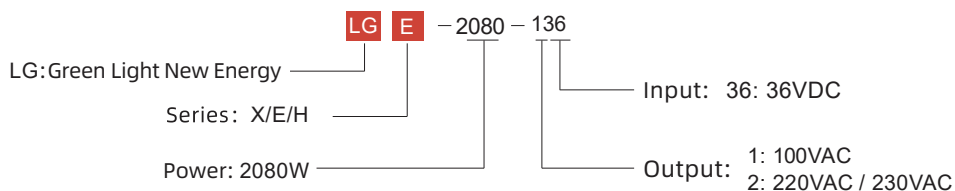

#### ■ Series Definition

| Model | Grade | Function   | Remark                |
|-------|-------|--|-----------------------|
| LGX   | 1     | Outdoor energy storage inverter power generation | more than 10000 hours |
| LGE   | 2     | Home solar (PV) energy storage power generation  | more than 20000 hours |
| LGH   | 3     | Industrial grade military industry               | more than 30000 hours |

### Product Specification Parameter

| MODEL NO.        | 2080W                            |  |
|------------------|----------------------------------|--|
| OUTPUT           | Rated Power (Typ .)              | 2080W  |
|                  | Maximum Output Power (1 Min)     | >2080W~2390W (100%~115%)   |
|                  | Surge Power ( Max . 1 Sec )      | > 4000W  |
|                  | AC Voltage                       | 100VAC   |
|                  | Frequency                        | 50/60 Hz±0.5%  |
|                  | Waveform                         | Pure sine wave (THD<3%)  |
|                  | AC Regulation (Typ .)            | ±5%  |
|                  | LED Indicator                    | Input voltage level, output load level and faulty status                               |
| INPUT            | DC Voltage                       | 36V DC   |
|                  | Voltage Range                    | 31.0~44.0V DC  |
|                  | No Load Current                  | 0.3A   |
|                  | Efficiency (80% .)               | 93%  |
|                  | Remote Standby Mode              | ≤ 0.08W  |
| PROTEC-TION      | Input Under - Voltage Protection | 30.0±0.5V DC   |
|                  | Input Under - Voltage Recovery   | 37.0±0.5V DC   |
|                  | Input Over - Voltage Protection  | 44.0±1.0V DC   |
|                  | Input Over - Voltage Recovery    | 42.0±0.5V DC   |
|                  | Output Overload                  | 2080W ≥ 115%<br>1 minute automatic shutdown output, automatic lock, restart to recover |
|                  | Output Short Circuit             | Output short circuit protection 3s shutdown lock, restart to recover                   |
|                  | Over Temperature                 | 85°C±5°C   |
|                  | DC Input Reverse Polarity        | By internal fuse open  |
| SAFETY& EMC      | Withstand Voltage                | Bat I/P-AC O/P:3 .0KVAC AC O/P -FG:1 .5KVAC  |
|                  | Isolation Resistance             | Bat I/P-AC O/P, Bat I/P - FG, AC O/P-FG:100M ohms / 500VDC/ 25C/70%RH                  |
|                  | EMC Emission                     | Compliance to FCC classA ,E-Mark EACTPTC 020 , EN55032 classA, 72/245/ CEE,95/54/CE    |
|                  | EMC Immunity                     | Compliance to EAC TPTC 020 , EN61000-4-2,3,4,5,6,8,11                                  |
| ENVIRON-<br>MENT | Working Temp                     | -30°C ~ 60°C   |
|                  | Working Humidity                 | 20~90% RH  |
|                  | Storage Temp, Humidity           | - 30~ +70 °C / -22~+158 F, 10~95% RH non-condensing                                    |
| OTHERS           | Dimension                        | 364.5*237*85mm   |
|                  | Packing                          | ≈ 3.8KG  |

Note1 - Normal Condition: Vin=25V / 36V / 50V Vo=100 / 110 / 115 / 120 VAC 80% Full load (PF=1 .0)

Note2 - Warning: This is a class A product. In a domestic environment this product may cause radio interference in which case the user may be required to take adequate measures .

### Protective Function

- 1) Low-voltage alarm: The buzzer sounds 2 times with 1 Hz gap.
- 2) Low voltage protection: The buzzer continuously sounds 3 times alarm, with 1 Hz gaps
- 3) Low-voltage recovery: the low-voltage rise automatically restores the output, and the buzzer sounds 3 times alarm is cancelled.
- 4) Overvoltage protection: The buzzer sounds 4 times, with 1 Hz gap.
- 5) Overvoltage recovery: The voltage is reduced automatically to restore the output, and the buzzer sounds 4 times alarm is cancelled.
- 6) Thermal protection: 85 ° ± 5 °, when overheat protection buzzer sounds 5 times alarm, with 1 Hz gap.
- 7) Overload protection: overload 100%~115% 60s Turn off , overload 116%~150% 3s Turn off, overload 151%~200% 1s Turn off, overload>200%,200ms Turn off,The buzzer blared .
- 8) Short circuit protection: Output short circuit protection 3s shutdown lock.

Derating Curve

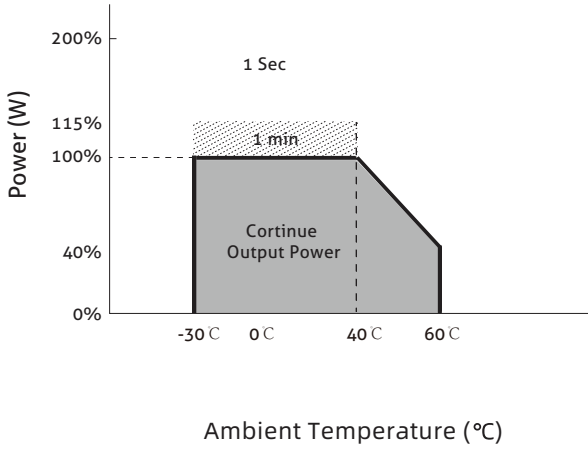

Ambient Temperature (°C)

curve 1

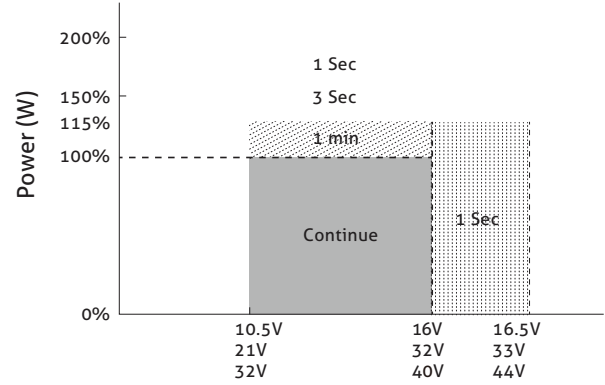

Battery input voltage( V )

curve 2

Introduction to Battery Schematic Diagram

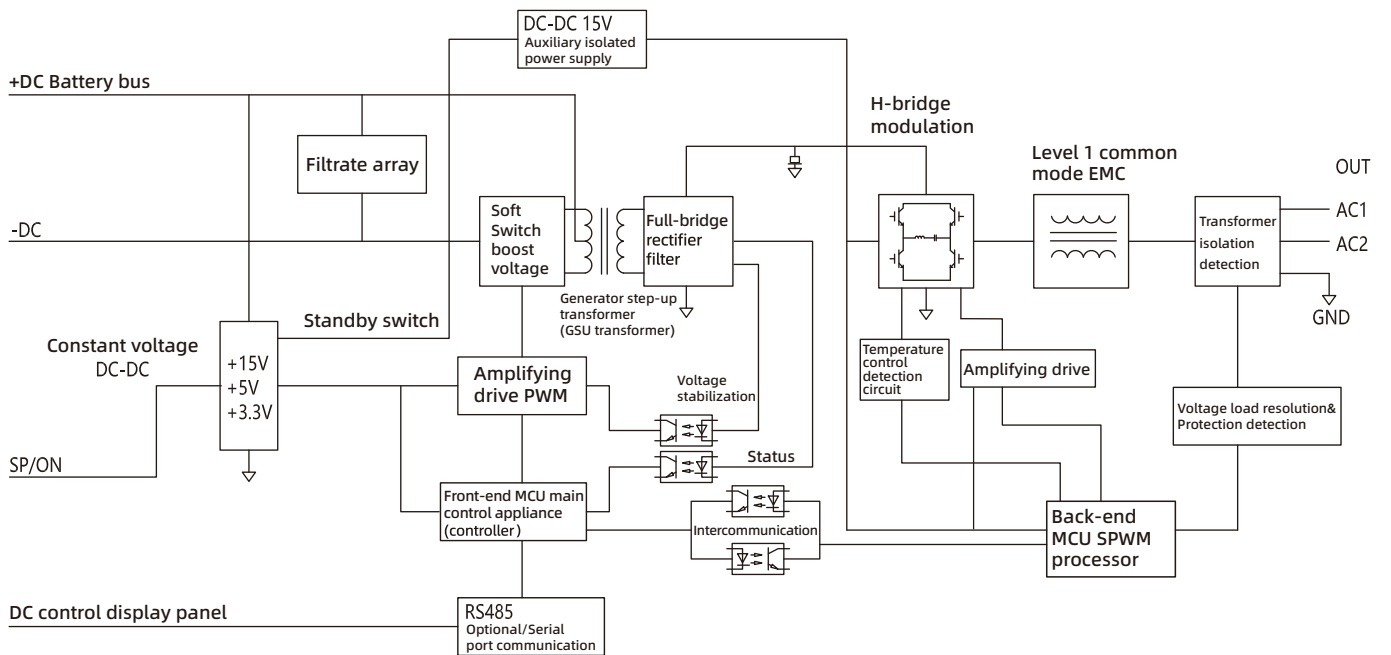

■ Lifespan

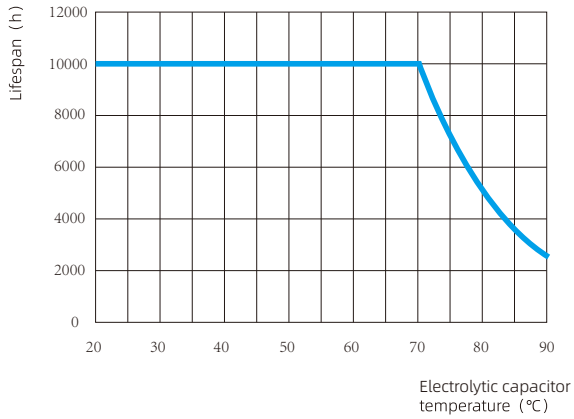

Input filtrate capacitance

(Remarks: The life is determined by the rationality of the air duct design of the chassis, and the effect of the fan air volume on the operating temperature of the inverter board against the above graph)

■ Dynamic Characteristic Curve

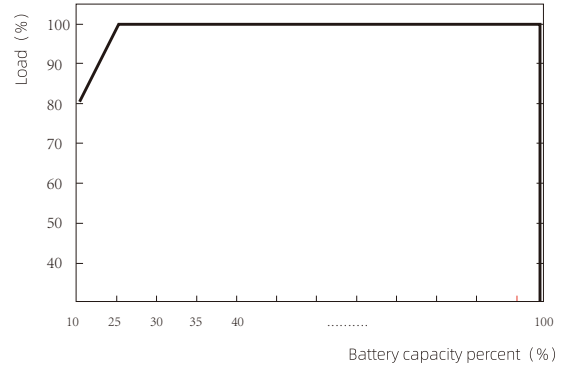

The load varies with the battery capacity by percent according to the above curve

■ Efficiency VS Load

36V model, ambient temperature 25 °C

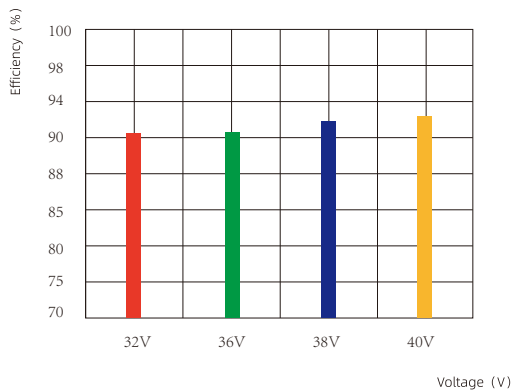

Efficiency Comparison of Full Load Power Output (2080W) at Different Input Voltages

36V model, ambient temperature 25 °C

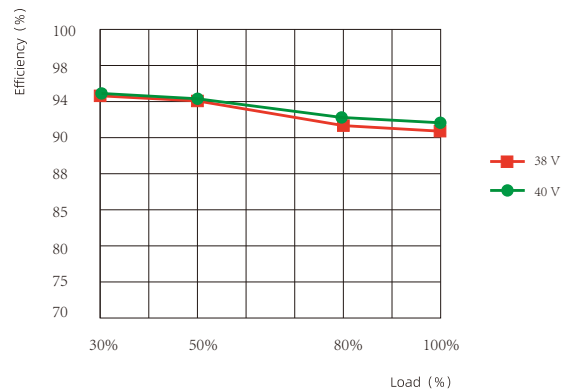

Efficiency Variation with Different Output Loads at Fixed Input Voltage

### Temperature Test Condition

#### Relationship between temperature and life

Test conditions: The purpose is to low voltage input when the current is the highest point, the overall circuit heating and heat dissipation is reasonable

Input voltage: 38.15V      Current: DC 59.1A  
Output voltage: AC 100V      Current: AC 21.02A  
Power: 2102W  
Conversion efficiency: 93.22%  
Time: work 1 hours heat stability

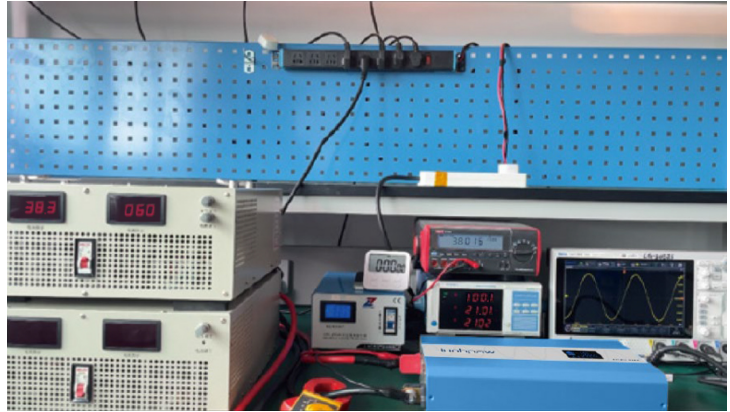

Front image

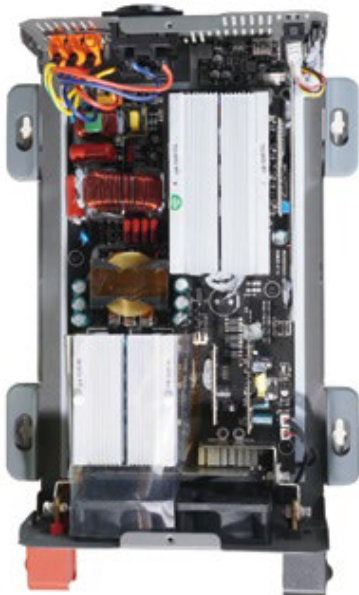

Frontal thermal image

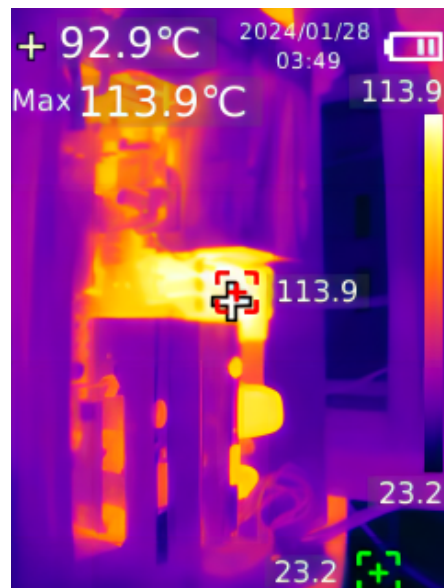

Sine Wave Output Waveform Diagram

No Load (8W):



Half Load (1040W):









Full Load (2080W):

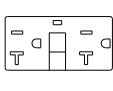

### ■ Interface Introduction



### Socket Types

|             |   |   |   |   |   |   |   |   |
|-------------|---|---|---|---|---|---|---|---|
| Socket type |  |  | <br><small>(Terminal inside case only, no AC socket)</small> |  |  |  |  | <br><small>(Terminal inside case only, no AC socket)</small> |
|             | Standard  | Optional  | Optional  | Standard  | Optional  | Optional  | Optional  | Optional  |
| Country     | USA   | GFCI (60Hz)   | —   | —   | AUSTRALIA   | U.K   | EUROPE  | —   |

### Product Appearance

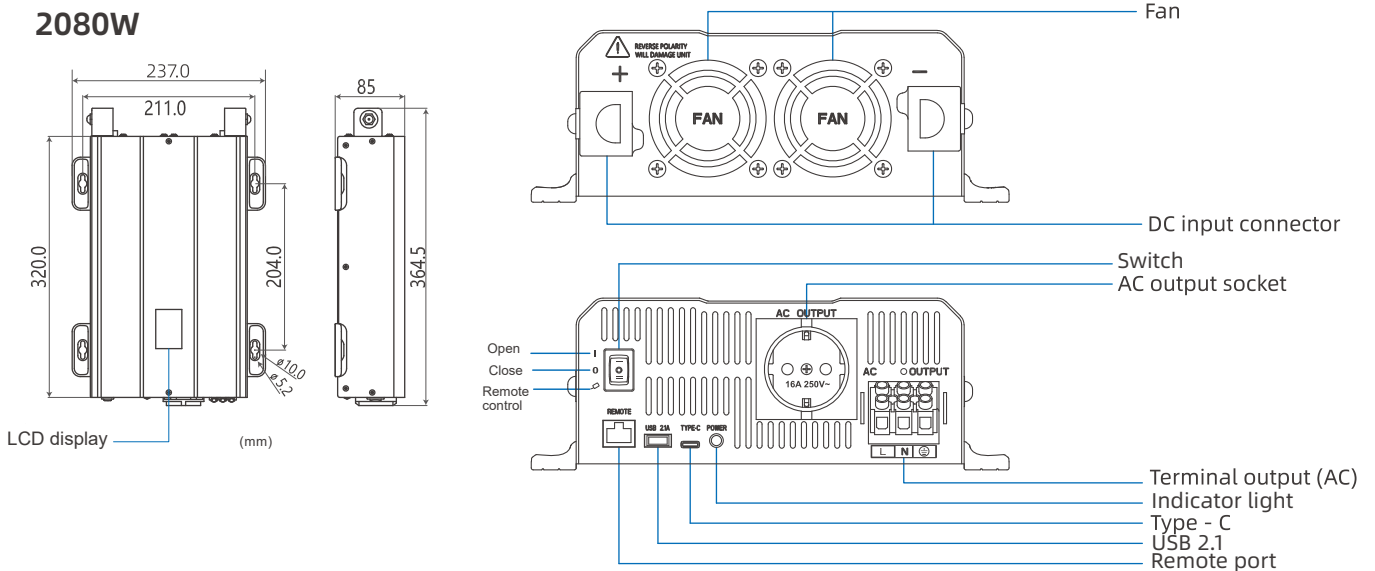

### Warning



#### Warning!

Do not open or disassemble the Inverter. Attempting to do so may cause risk of electrical shock or fire.

We guarantee this product against defects in materials and workmanship for a period of 24 months from the date of purchase.

In case you need to repair or replace any defective power inverters, please contact local distributor.

This warranty will be considered void if the unit has been misused, altered, or accidentally damaged. Our is not liable for anything that occurs as a result of the user's fault.