



■ Features

- Can continuously carry 3080 watts of internal resistance load, Peak power up to 9240/200ms.
- No load power (10W).
- With the most advanced load resolution, overload protection, short circuit protection technology.
- With input multiple voltage range options 12,24,36,48V, output 110/220V frequency:50/60Hz.
- Lifespan more than 10000 hours(5 hours per day and more than 5 years).

■ Description

The LGE-3080W series is an inverter designed by the Power Division of Shenzhen Green Power New Energy Co., Ltd. The design concept is based on the principle of AC power generators. By using software-based SPWM integral calculus algorithm and LC resonant modulation technology, it achieves the optimal output of pure sine wave AC power for loads, with high compatibility and load-bearing capacity as its design features. With a high conversion efficiency of up to 94%, it employs intelligent fan management control, allowing it to operate in environments ranging from -30 degrees to 60 degrees Celsius.

■ Application

- Electric cooker
- Hairdryer
- Air conditioner
- Teakettle
- Multifunctional pot appliance
- Portable electric working tools and other common daily electrical appliances

■ Model Code

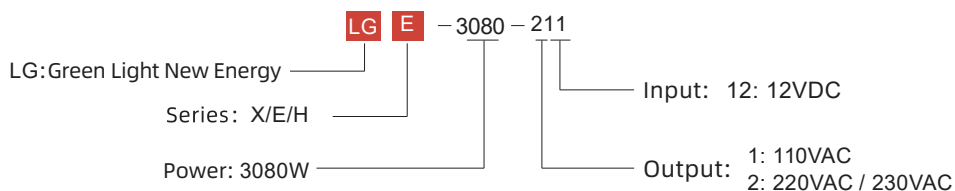

■ Series Definition

Model	Grade	Function	Remark
LGX	1	Outdoor energy storage inverter power generation	more than 10000 hours
LGE	2	Home solar (PV) energy storage power generation	more than 20000 hours
LGH	3	Industrial grade military industry	more than 30000 hours

Product Specification Parameter

MODEL NO.	3080W	
OUTPUT	Rated Power (Typ .)	3080W
	Maximum Output Power (1 Min)	> 3080W~3160W (100%~115%)
	Surge Power (Max . 1 Sec)	> 6160W
	AC Voltage	100/ 110/ 115/ 120VAC
	Frequency	50/60 Hz±0.5%
	Waveform	Pure sine wave (THD<3%)
	AC Regulation (Typ .)	±5%
	LED Indicator	Input voltage level, output load level and faulty status
INPUT	DC Voltage	12VDC
	Voltage Range	10 .5~16 .5VDC
	No Load Current	0.8 A
	Efficiency (80% .)	89%
	Remote Standby Mode	≤ 0.08W
PROTEC-TION	Input Under - Voltage Protection	10 .0±0 .3VDC
	Input Under - Voltage Recovery	12 .5±0 .3VDC
	Input Over - Voltage Protection	16 .5±1 .0VDC
	Input Over - Voltage Recovery	15 .0±0 .5VDC
	Output Overload	3080W ≥ 115% 1 minute automatic shutdown output, automatic lock, restart to recover
	Output Short Circuit	Output short circuit protection 3s shutdown lock, restart to recover
	Over Temperature	85°C±5°C
	DC Input Reverse Polarity	By internal fuse open
SAFETY& EMC	Withstand Voltage	Bat I/P-AC O/P:3 .0KVAC AC O/P -FG:1 .5KVAC
	Isolation Resistance	Bat I/P-AC O/P, Bat I/P - FG, AC O/P-FG:100M ohms / 500VDC/ 25°C/70%RH
	EMC Emission	Compliance to FCC classA ,E-Mark EACTPTC 020 , EN55032 classA, 72/245/ CEE,95/54/CE
	EMC Immunity	Compliance to EAC TPTC 020 , EN61000-4-2,3,4,5,6,8,11
ENVIRON-MENT	Working Temp	-30°C ~ 60°C
	Working Humidity	20~90% RH
	Storage Temp, Humidity	-30~ +70C / -22~+158 F, 10~95% RH non-condensing
OTHERS	Dimension	404.5*265*70mm
	Packing	≈ 5.8KG

Note1 - Normal Condition: Vin=12 .5V / 25V / 50V Vo=100 / 110 / 115 / 120 VAC 80% Full load (PF=1 .0)

Note3 - Warning: This is a class A product . In a domestic environment this product may cause radio interference in which case the user may be required to take adequate measures .

Protective Function

- 1) Low-voltage alarm: The buzzer sounds 2 times with 1 Hz gap.
- 2) Low voltage protection: The buzzer continuously sounds 3 times alarm, with 1 Hz gaps
- 3) Low-voltage recovery: the low-voltage rise automatically restores the output, and the buzzer sounds 3 times alarm is cancelled.
- 4) Overvoltage protection: The buzzer sounds 4 times, with 1 Hz gap.
- 5) Overvoltage recovery: The voltage is reduced automatically to restore the output, and the buzzer sounds 4 times alarm is cancelled.
- 6) Thermal protection: 85 ° ± 5 °, when overheat protection buzzer sounds 5 times alarm, with 1 Hz gap.
- 7) Overload protection: overload 100%~115% 60s Turn off , overload 116%~150% 3s Turn off, overload 151%~200% 1s Turn off, overload>200%,200ms Turn off, The buzzer blared .
- 8) Short circuit protection: Output short circuit protection 3s shutdown lock.

Derating Curve

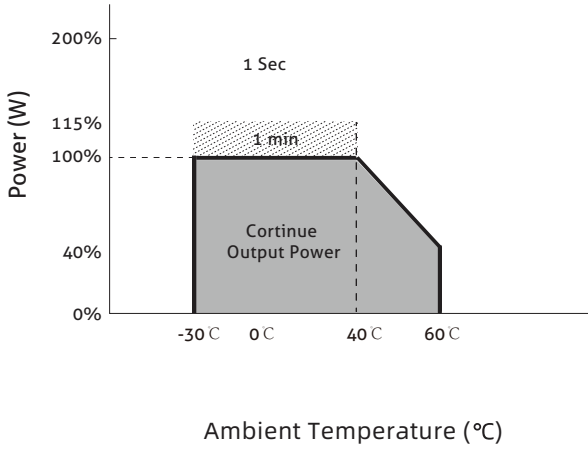

Ambient Temperature (°C)

curve 1

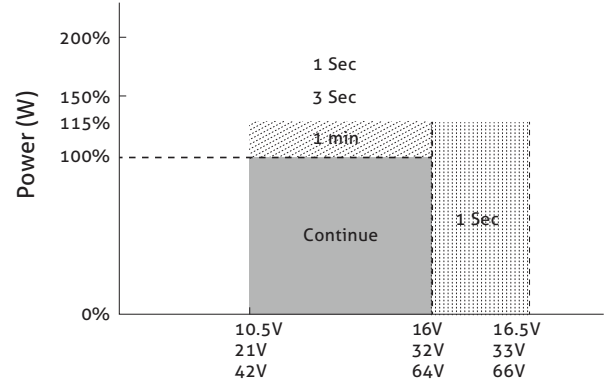

Battery input voltage(V)

curve 2

Introduction to Battery Schematic Diagram

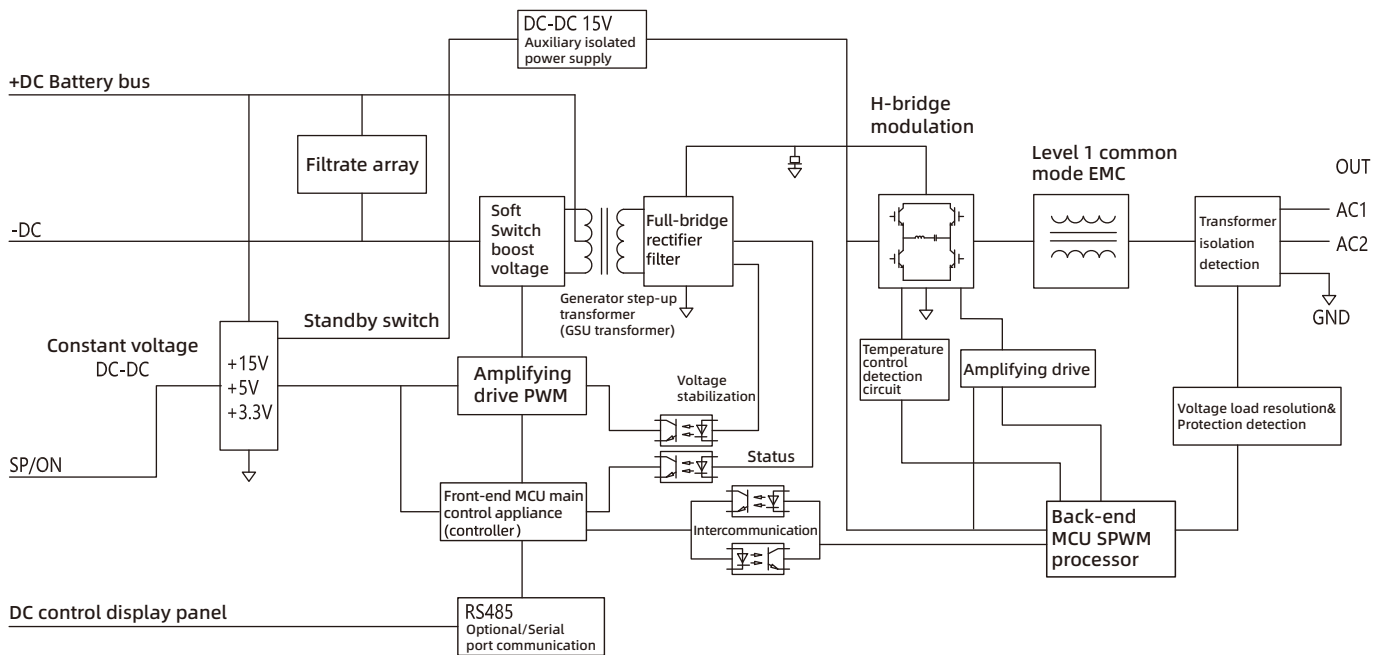

■ Lifespan

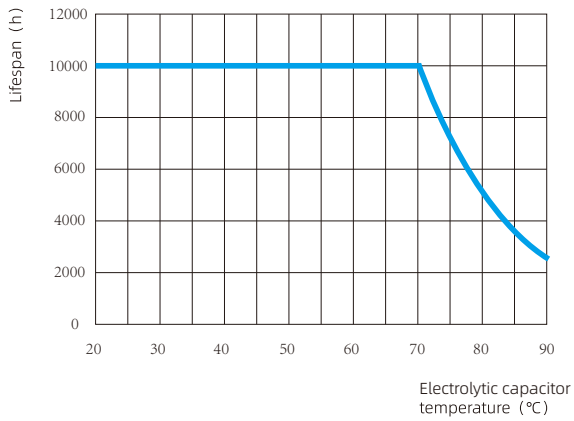

Input filtrate capacitance

(Remarks: The life is determined by the rationality of the air duct design of the chassis, and the effect of the fan air volume on the operating temperature of the inverter board against the above graph)

■ Dynamic Characteristic Curve

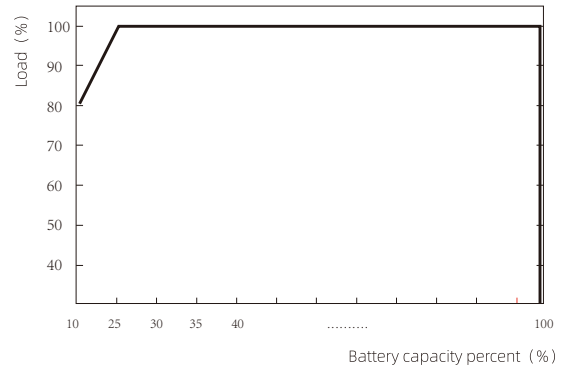

The load varies with the battery capacity by percent according to the above curve

■ Efficiency VS Load

12V model, ambient temperature 25 °C

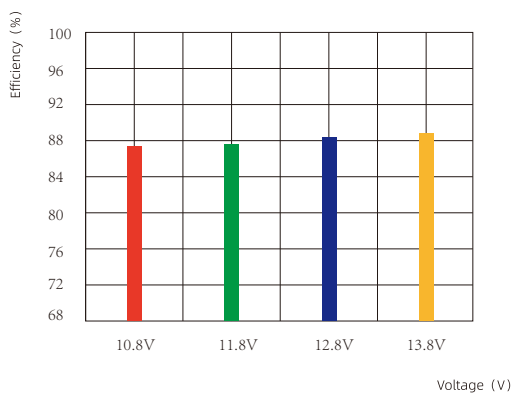

Efficiency Comparison of Full Load Power Output (3080W) at Different Input Voltages

12V model, ambient temperature 25 °C

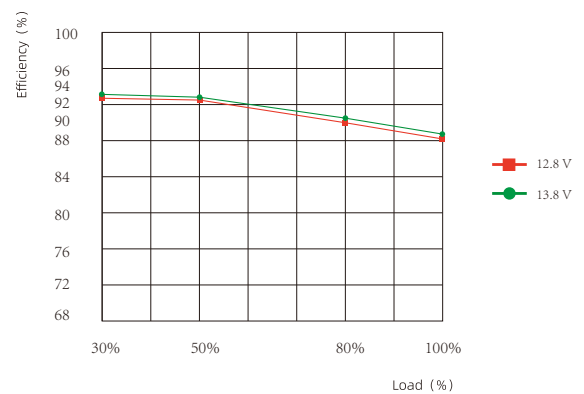

Efficiency Variation with Different Output Loads at Fixed Input Voltage

Temperature Test Condition

Relationship between temperature and life

Test conditions: The purpose is to low voltage input when the current is the highest point, the overall circuit heating and heat dissipation is reasonable

Input voltage: 12.68V Current: DC 268.5A
Output voltage: AC 110.9V Current: AC 27A
Power: 3005W
Conversion efficiency: 88.26%
Time: work 1 hours heat stability



Front image

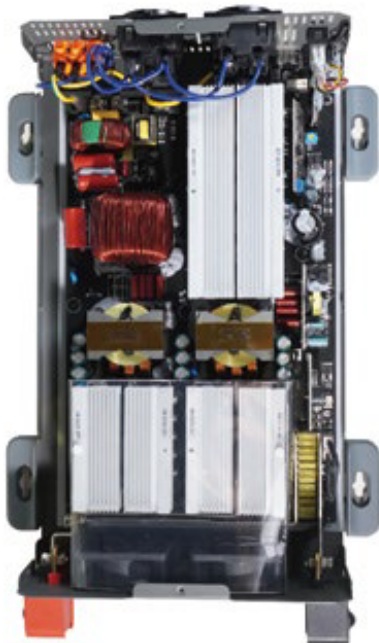

Frontal thermal image

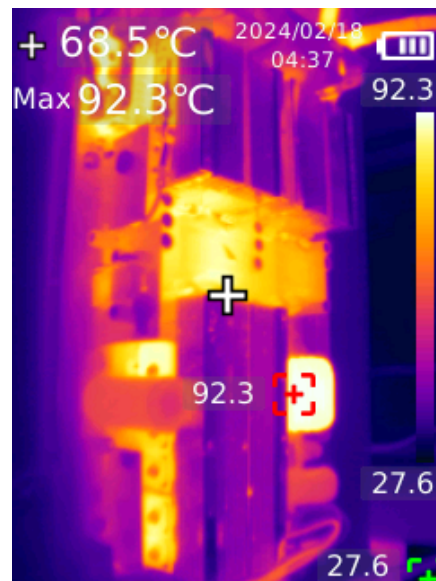

■ Sine Wave Output Waveform Diagram

No Load (10W):



Half Load (1540W):



Full Load (3080W):



■ Interface Introduction

Positive Battery Terminal

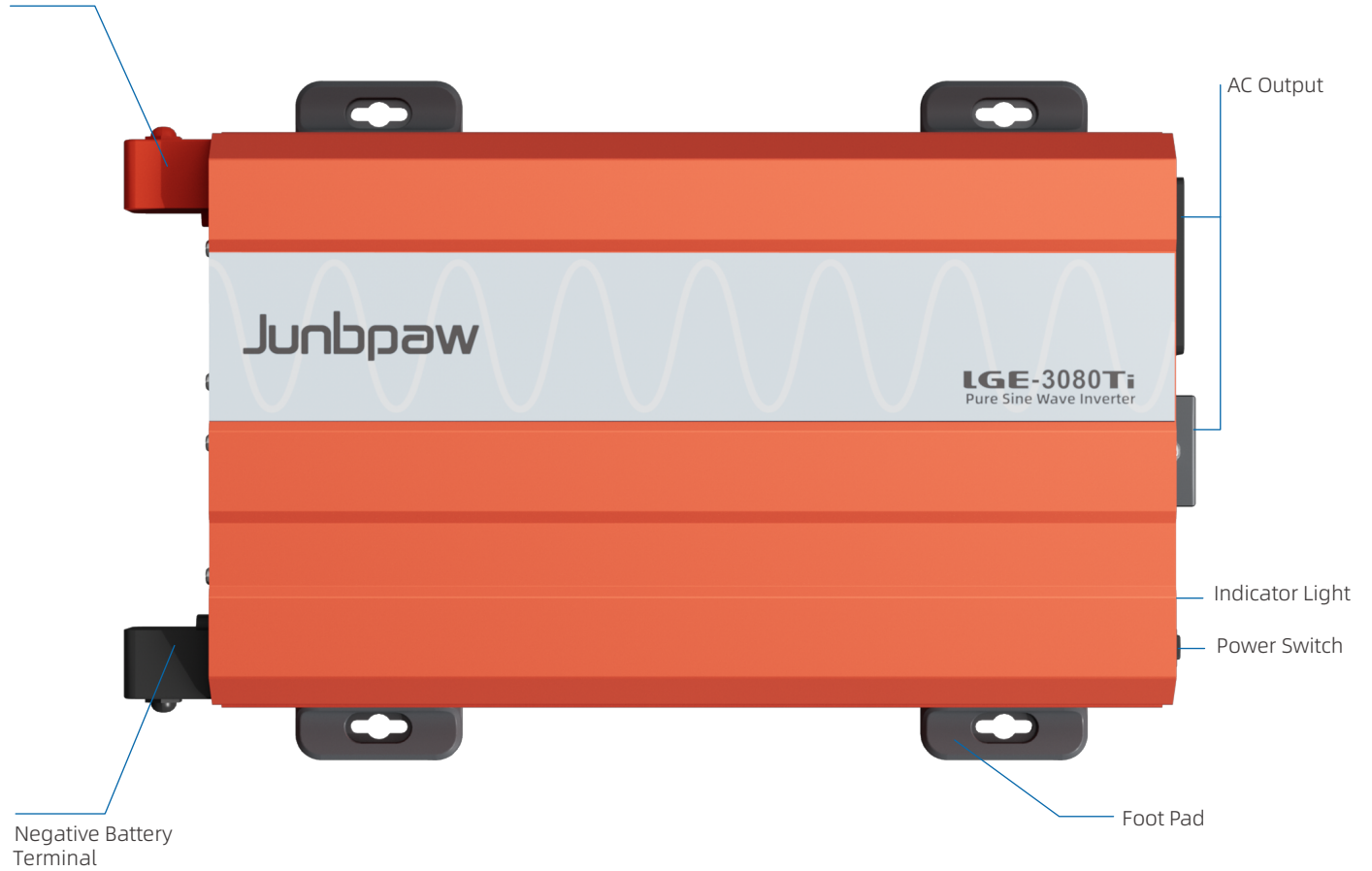

AC Output







Indicator Light

Power Switch

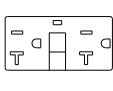
Negative Battery Terminal

Foot Pad

Socket Types

Socket type			 <small>(Terminal inside case only, no AC socket)</small>					 <small>(Terminal inside case only, no AC socket)</small>
	Standard	Optional	Optional	Standard	Optional	Optional	Optional	Optional
Country	USA	GFCI (60Hz)	—	—	AUSTRALIA	U.K	EUROPE	—

Product Appearance

3080W

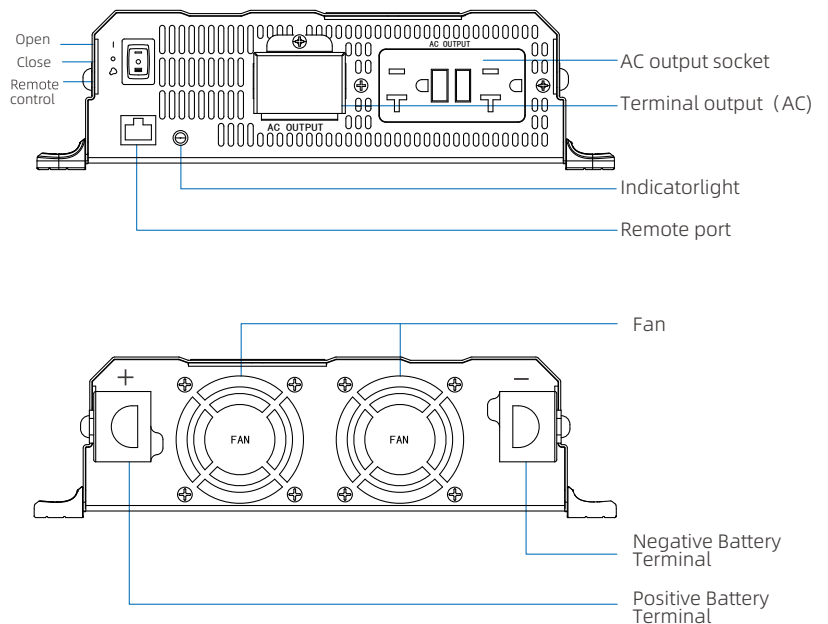
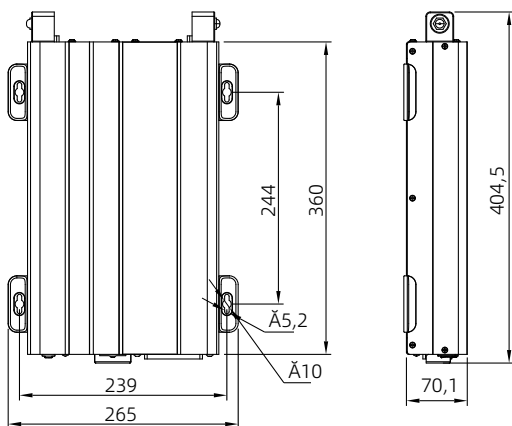

Warranty



Warning!

Do not open or disassemble the Inverter. Attempting to do so may cause risk of electrical shock or fire.

We guarantee this product against defects in materials and workmanship for a period of 24 months from the date of purchase.

In case you need to repair or replace any defective power inverters, please contact local distributor.

This warranty will be considered void if the unit has been misused, altered, or accidentally damaged. Our is not liable for anything that occurs as a result of the user's fault.